

# Schindler 3300

## Traction elevator installation checklist



# Schindler 3300

## Traction elevator installation checklist

### Delivery of equipment

Prior to elevator equipment delivery, an enclosed dry hoistway, a ready machinery space and temporary or permanent three-phase power must be available.

### General Contractor

- Provide adequate, rollable access for delivery and material unloading, and a dry place for storage of equipment located near hoistway.
  - Refer to elevator layout. Please verify hoistway finished clear width and depth, pit depth, floor-to-floor heights, and clear overhead.
  - Build a clear, plumb, legal hoistway in accordance with applicable code from top to bottom with variations not to exceed 1" (25.4 mm) per 100' (2540 mm).
  - Provide attachment points for elevator rail brackets. Locate per layout.
  - Provide a temporary work platform at the top floor of each hoistway for elevator construction; see Detail A.
- C1**– Vent at the top of hoistway to be located on side opposite of the machine. Check local codes for ventilation requirements. Refer also to Ventilation Requirements.
- C2**– Supply hoist beam for elevator construction and service work. Beam to run across the width of the elevator shaft. Loads and location per elevator layout.

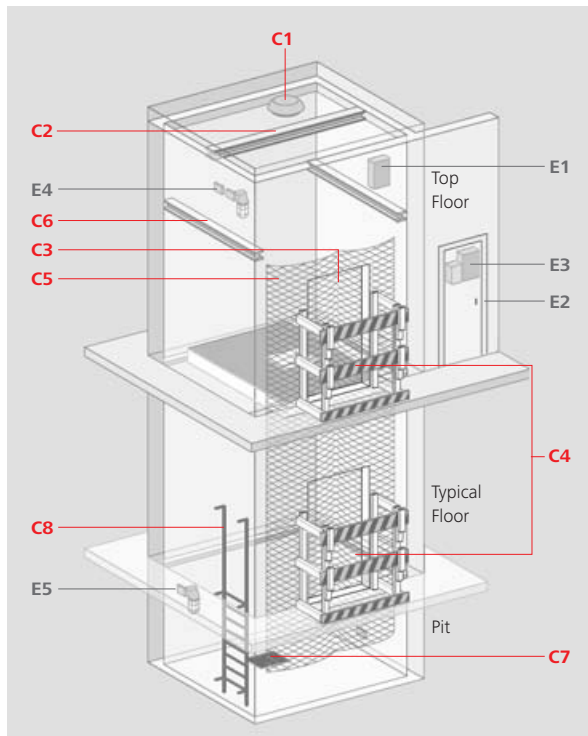

### Hoistway walls

- C3**– Masonry: Provide opening of +8" (203 mm) on each side and +4" (102 mm) on top of clear opening for installation of door frames and sills by Schindler.
- Dry wall: Walls at entrance to be built after door sills and frames are set in place.
  - Grout entrances and sills after installation by Schindler.
  - No conduit, duct or piping allowed in the hoistway that is not related to the elevator equipment.
  - Pit and hoistway must be dry at all times.
  - If job requires cutting and patching of walls, floors, etc., and removal of such obstruction for proper installation of the elevator as well as pockets or blockouts for signal fixtures, it is to be done by General Contractor. Refer to elevator layout. Seal all wall penetrations with material approved by code to maintain fire rating.
- C4**– OSHA-approved barricades must be installed with kick board at each opening.
- C5**– Debris netting to be installed to protect each landing entrance from other trades materials and equipment.
- C6**– Attachment points for elevator rail bracket supports (inserts, steel or concrete) are needed at all floor levels and in the overhead at 8'-2" above top landing. Supports between floors may be necessary per code if span is excessive. Coordinate locations with Schindler.
- Bevel all hoistway projections and recesses in accordance with applicable codes.
  - Divider beams are required between adjacent elevators at all floor levels and at 8'-2" above top landing. Locate per layout.

### Pit

- C7**– Provide drain or sump hole in pit as required by governing local code. Cover for sump shall be level with pit floor. Drains connected directly to sewers shall not be installed in elevator pits. Location to be coordinated with Schindler. Pit must be dry at all times.
- C8**– Pit ladder may be supplied by Schindler if a collapsible pit ladder is necessary.

### Machinery space

- Temperature of machinery spaces must be maintained as follows for proper operation of equipment.
  - Hoistway: Between 32° F (0° C) & 110° F (43° C)
  - Top Landing: Between 32° F (0° C) & 104° F (40° C)
- No conduit, duct or piping allowed in machinery spaces that is not related to the elevator equipment.
- Provide fire extinguisher (type ABC) within sight of top landing entrance.
- Provide live analog phone line.

## Electrical Contractor

- Must immediately confirm the type of three-phase power to the elevator equipment room (208 volt, 460 volt, 480 volt, 575 volt or 600 volt) and provide before work can begin. Refer to Schindler power data sheet for approval.
- E1– Provide a non-fused, enclosed, externally-operable motor circuit switch capable of being locked in the open position as a means to disconnect power from the machine in the hoistway overhead. This switch is to be in line of sight of the motor controller located on the front wall of the hoistway.
- E2– Provide a fused, heavy duty, three-phase, lockable disconnect or shunt trip breaker in a machinery space accessible from outside of the hoistway with feeder branch wiring to the non-fused switch in the hoistway. Disconnect size to suit elevator contractor's equipment requirements. All work must be per National Electric Code and ASME A17.1 and any local codes. Locate per layout.
  - Where transformers are necessary to provide the proper voltage to the operation controller or motor controller. Locate per layout.
- E3– Provide a 110V single-phase lockable disconnect (for car lighting and fan) in the machinery space accessible from outside of the hoistway with feeder branch wiring to elevator controller. Disconnect size to suit elevator contractor's equipment requirements. All work must be per National Electric Code, ASME A17.1 and any local codes. Locate per layout.
- E3– Provide a 110V single-phase lockable disconnect (for top hoistway machinery space lighting) in the machinery space accessible from outside of the hoistway with feeder branch wiring to elevator controller. Disconnect size to suit elevator contractor's equipment requirements. All work must be per National Electric Code, ASME A17.1 and any local codes. Locate per layout.
- E3– Provide a 110V single-phase lockable disconnect (for hoistway pit lighting) in the machinery space accessible from outside of the hoistway with feeder branch wiring to elevator controller. Disconnect size to suit elevator contractor's equipment requirements. All work must be per National Electric Code, ASME A17.1 and any local codes. Locate per layout.
  - If sprinklers are required, provide smoke-sensing devices at elevator lobbies and/or at top of elevator shaft, with electrical conductors terminating at elevator controller in machinery space for automatic elevator recall system in the event of a fire.

- Shunt trip breaker required if sprinkler in pit, hoistway or machine room.
- E4– Provide adequate lighting and receptacle in machinery spaces. Locate per layout.
  - Per the latest National Electrical Code, all receptacles installed in machinery spaces and pits must have Ground Fault Circuit Interrupter Protection (GFCI).
- E5– Provide a light and receptacle in elevator pit. Locate per layout.

## Schindler Elevator Corporation

- Supplies telephone in car and travel cable to car.

### Machine space considerations

All wiring (including analog phone line) to machinery space supplied by owner.

### Local codes may vary. Consult with your architect/engineer and local Schindler representative.

### Sound suppression

The following guidelines are to be followed to reduce noise to acceptable levels:

1. The surrounding walls, floor, and ceiling assembly should have a substantial STC (Sound Transmission Class) rating. The higher the STC rating, the better. If noise-sensitive areas are nearby, STC 50 or 55 should be used as the design criteria for the surrounding structure. Concrete block walls will provide STC 42. Two layers of gypsum board on each side of 3 5/8" steel studs at standard spacing (total of four layers, two on each side) with fiberglass batt in the cavity will provide STC 56. All cracks and gaps around the perimeter must be copiously filled with the appropriate acoustical caulking. Wood studs should be avoided, but if they are used, attach drywall with resilient channel or use a staggered stud arrangement.
2. In situations where noise-sensitive areas are not an issue, two layers of drywall (four total) are still recommended and sufficient caulk around the perimeter. Double-layer drywall with staggered seams works best.
3. Penetrations into the hoistway must be kept to a minimum. When conduits pass through the walls, they must be sealed with mortar or the appropriate acoustical sealant to prevent noise leaks. A heavy, solid material must be used. Do not use fiberglass.
4. If the walls are concrete block, do not paint them. Unpainted block has about 33% absorption, which is lost with a coat of paint.

# Schindler 3300

## Traction elevator installation checklist

### Ventilation requirements

These guidelines are to be followed to maintain acceptable elevator equipment room temperatures.

- Temperature of machinery spaces must be maintained as follows for proper operation of equipment.
  - Hoistway: Between 32° F (0° C) and 110° F (43° C)
  - Top Landing: Between 32° F (0° C) and 104° F (40° C)
- Minimum machinery space ventilation requirements for Schindler 3300 elevators:

Rated HP	BTU/hr	CFM*
5.2 [FMB130-4M576-NA]	5050	258
5.2 [FMB130-4M256-NA]	5160	263
7.8 [FMB130-4M464-NA]	5120	261
7.8 [FMB130-4M192-NA]	5540	283
7.1 [FMB150-6D540-NA]	3880	198
7.1 [FMB150-6D234-NA]	4100	209
10.6 [FMB150-6D396-NA]	4330	220
10.6 [FMB150-6D162-NA]	5240	267

\* Minimum air at 70° F to be moved in and out of the machine room.

### Detail A

#### Temporary work platform

##### 2100 lb capacity car

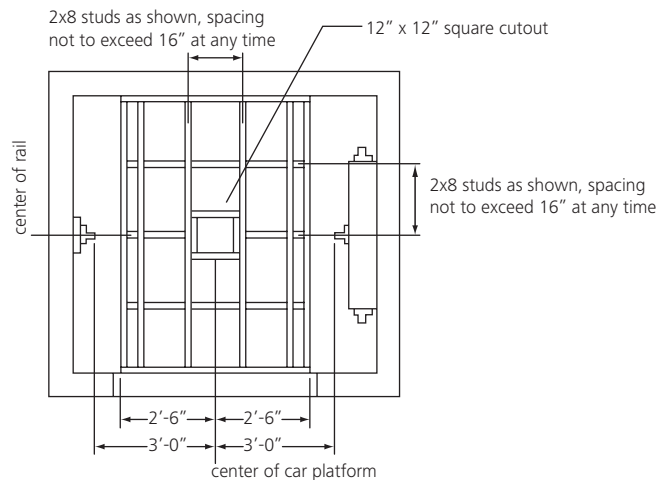

##### 2500 lb, 3000 lb and 3500 lb capacity cars

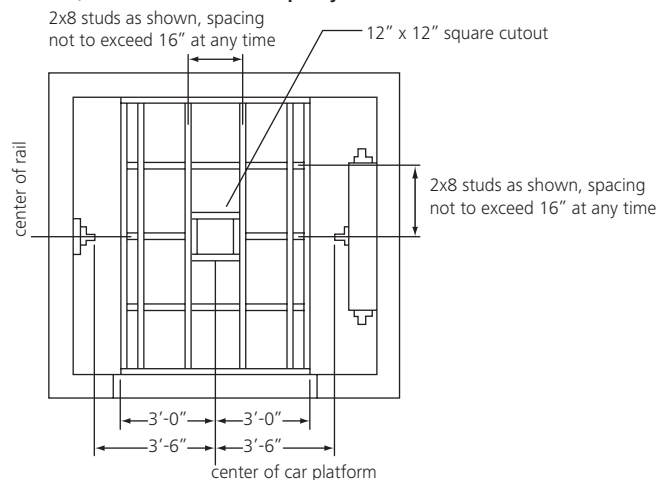

#### Notes:

- All 2x8s to be grade 2, Douglas Fir, free of knots.
- Platform to be covered by .75' plywood.
- Plywood decking to be .75' thick CDX grade, tongue and groove.
- Platform mounting to hold load of 1500 lb.

For further information, including location of the Schindler office nearest you, please contact:

U.S. Headquarters. Morristown, New Jersey

Toll-Free 877.696.8382

[www.us.schindler.com](http://www.us.schindler.com)

Canada Headquarters. Toronto, Ontario

Tel. 416.332.8280

[www.ca.schindler.com](http://www.ca.schindler.com)



Schindler is a member organization of the U.S. Green Building Council.



Schindler has received renewal to ISO 14001:2004 and ISO 9001:2008 certificates.



Schindler prints with vegetable-based ink on paper containing post-consumer waste fiber.